



MKF 2S SW2.4LE-MED SK13

Part-No.: 1274508

## Specification

- baseplate SK13 with safety flap
- battery compartment
- position sensor
- LED indication for battery status and transmission
- steute wireless (SW2.4LE)

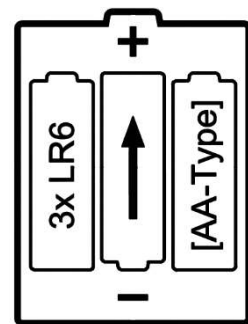
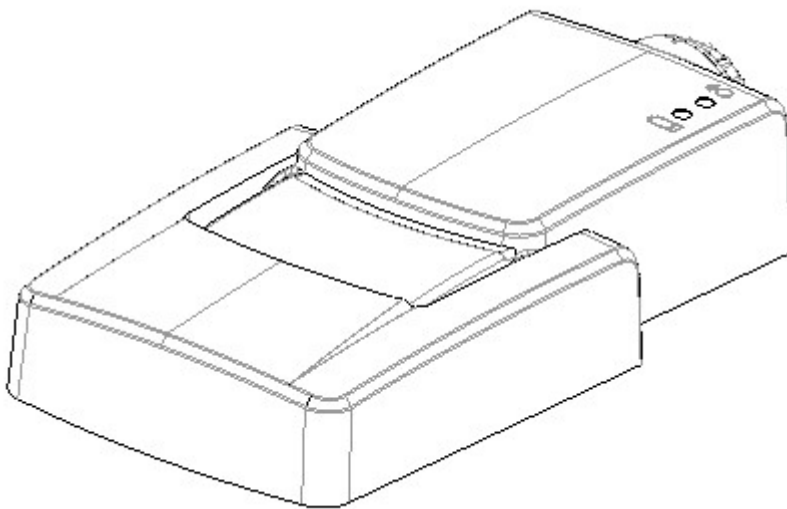

batterie: 3xLR6 (1,5 V DC)  
=>2900 mAh

## Technical Data

Applied standards	IEC 60601-1 (Basic Safety) IEC 60601-1-2 IEC 60601-2-2 IEC 60601-2-22 IEC 60601-2-43 IEC 60529 (Degrees of protection)  Note: see CSA certificate for corresponding revision level.
Existing certifications	CSA
Enclosure	shockproof thermoplastic, self-extinguishing / Pantone cool grey 1C
Pedals	shockproof thermoplastic, self-extinguishing / black
Pedal enclosure	shockproof thermoplastic, self-extinguishing / black
Degree of protection	IPX8 (1m / 35 Min.) as per DIN EN 60529
Contact element/material	Pedals: Reed/rhodium
Rated operating voltage (Ue)	Battery: 3xLR6 (1,5 V DC) = 4,5 V DC / batteries not included in scope of delivery
Mechanical lifetime	> 1 Mio. operations
Dimension	120 x 239 x 51 mm
Weight	0,9 kg



MKF 2S SW2.4LE-MED SK13  
Part-No.: 1274508

## Radio specifications

<b>Performance</b>	
Distance:	10 m -30 m (with internal antenna, depends on spatial conditions and the surrounding)
Output rating:	3 dBm (max. 7 dBm optional)
Input sensitivity:	-93 dBm
Antenna:	Internal antenna with U.FL-plug
<b>Radio technology</b>	
Frequency range:	2402 to 2480 MHz
Chanel spacing:	2 MHz
Modulation:	GFSK, adaptive frequency hopping of 40 channels
<b>Applied radio standards</b>	
Europa	EN 300 328 V2.1.1, EN 301 489-1 V2.2.0, EN 301 489-17 V3.2.0
<b>Transmitter and radio module</b>	
USA	<b>FC</b> , Part 15C , single Modular, Identifier: XK5-SW24LE
Canada	RSS-247 Issue 1, Identifier: 5158A-SW24LE
Japan	ARIB STD-T66, Identifier: 204-650001

Please note the instruction manual for the SW2.4LE system (D023336) (Document on request)

## Environmental conditions

	Storage/Transport (without batteries)	Operating
Temperature range	-20 °C up to +60 °C	0 °C up to +45 °C
Relative humidity	10 % up to 100 %	10 % up to 100 %
air pressure	500 hPa – 1060 hPa	700 hPa – 1060 hPa

## General notes

The foot switch as a component of a medical device can be evaluated only together in the overall system of the customer. Therefore the conformity evaluation including the classification of the overall system according to the Medical Device Directive 93/42/EEC respectively EU Medical Device Regulation 2017/745 must be carried out at the customer. In addition, validation can also only be carried out by the customer in the overall system.

Furthermore, the intended use and the basic functions are verifiable only in interaction with the overall system. As a result, the customer must involve the footswitch in his risk management, his usability analysis, the verification of the electromagnetic compatibility and, if applicable, the verification of the biocompatibility.

Please refer to the Technical Description (D031289) for Medical synthetic footswitch SW2.4LE-MED/ battery-powered

## Maintenance/cleaning

- During cleaning, avoid wiping with a cloth under the pedal, because this may cause the springs to move out of position.



MKF 2S SW2.4LE-MED SK13

Part-No.: 1274508

## Safety instructions

Despite careful production and inspection as well as redundant design of important components, an entirely safe function cannot be guaranteed at all times (in case of malfunction, for example, a switch contact can turn off incorrectly, or a spring may break).

A functional test must be performed before every operation.

Risk of injury due to incorrect handling!

- The plug connections must not be subjected to mechanical loads!
- Switch off terminal before cleaning or maintenance work!
- Test functions when device is switched back on!
- Moving actuating components (e.g. carrying handle) can be a crushing hazard!
- Tripping hazard!

If components with reed contacts or hall sensors are used, strong magnetic fields can result in unwanted influences to the system. Additionally, magnetically conducting materials are to be kept away from the direct foot switch area!

The electrical connection may only be carried out by authorized personnel.

Components, especially pedals or other actuating elements, may not be disassembled or dismembered under any circumstances! If this happens the products need to be sent back immediately.

Errors and omissions excepted.