



Product name: MKF 2 2PW/2PW-MED GP26

Part-no.: 1236426

Specification

- Base plate in RAL 7035 Light grey with stainless steel hinged handle
- Additional push button in black
- Neutral pedals in black with two change-over contacts, connected as NO-contacts
- All contacts with common supply
- 3 m shielded cable

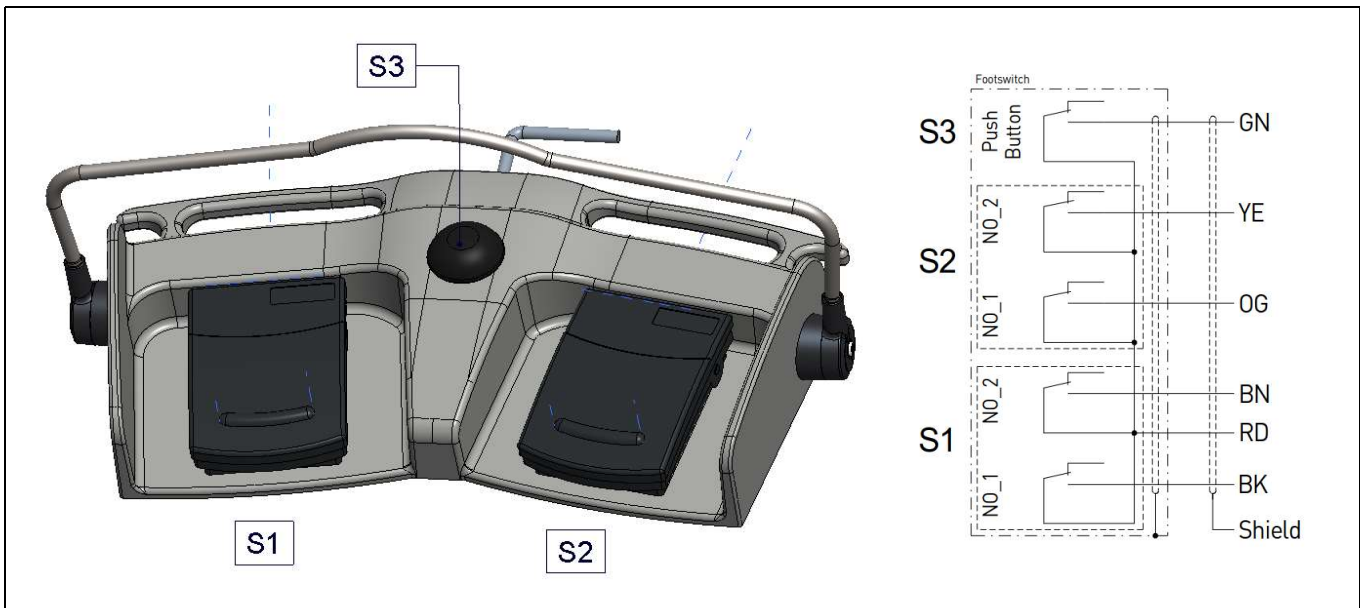

Technical Data

Applied standards	IEC 60601-1 (Basic Safety) IEC 60529 (Degrees of protection) Note: see CSA certificate for corresponding revision level.
Existing certifications	CSA CCC
Enclosure	GD-Al alloy, coated / RAL 7035 Light grey
Pedals	shockproof thermoplastic, self-extinguishing / black
Pedal enclosure	shockproof thermoplastic, self-extinguishing / black
Actuator	B7 / black
Degree of protection	IPX8 (1m / 35 Min.) according to DIN EN 60529
Contact element and material	Pedals: 2 micro switches / gold-plated, wired as NO contacts actuator: micro switch / silver-plated, wired as NO contact
Connection type	3 m shielded cable (6xAWG20 C UL RAL7035)
Mechanical lifetime	The expected operating life of the foot switch is limited to 10 years or 1,000,000 switching cycles of the actuating units, whichever comes first.
Dimension	376 x 190 x 159 mm
Weight	2,8 kg



Product name: MKF 2 2PW/2PW-MED GP26

Part-no.: 1236426

Electrical Ratings

Switching voltage (U_B):	max. 25 V AC / 60 V DC
Switching current (I_B):	max. 1 A
Switching capacity (P_B):	max. 20 W

Environmental Conditions

	Storage/Transport	Operating
Temperature range	-40 °C up to +70 °C	-10 °C up to +60 °C
Relative humidity	10 % up to 100 %	10 % up to 100 %
Air pressure	500 hPa – 1120 hPa	800 hPa – 1060 hPa

Mounting/Wiring

Wire the foot switches according to the specified wire colours/terminal labelling. Contact symbols are shown for a not actuated switch.

Maintenance

Depending on the environmental/operating conditions we recommend routine maintenance as follows:

- Check enclosure and connecting cable for damage and destructive dirt
- Check functional elements and actuating elements for free operation
- For only manual cleaning, use just a cloth impregnated with water and a mild detergent.
- Do not use cleaning agents which may damage the plastic surfaces such as detergents, abrasive cleansers or solvent-based cleaners (such as benzine, stain remover).
- During cleaning, avoid wiping with a cloth under the pedal, because this may cause the springs to move out of position.

Disposal

- Observe national, local and legal regulations concerning disposal.
- Recycle each material separately.



Product name: MKF 2 2PW/2PW-MED GP26

Part-no.: 1236426

General notes

The foot switch as a component of a medical device can be evaluated only together in the overall system of the customer. Therefore the conformity evaluation including the classification of the overall system according to the Medical Device Directive 93/42/EEC respectively EU Medical Device Regulation 2017/745 must be carried out at the customer. In addition, validation can also only be carried out by the customer in the overall system.

Furthermore, the intended use and the basic functions are verifiable only in interaction with the overall system. As a result, the customer must involve the footswitch in his risk management, his usability analysis, the verification of the electromagnetic compatibility and, if applicable, the verification of the biocompatibility.

Safety instructions

Despite careful production and inspection as well as redundant design of important components, an entirely safe function cannot be guaranteed at all times (in case of malfunction, for example, a switch contact can turn off incorrectly, or a spring may break).

A functional test must be performed before every operation.

Risk of injury due to incorrect handling!

- The plug connections must not be subjected to mechanical loads!
- Switch off terminal before cleaning or maintenance work!
- Test functions when device is switched back on!
- Moving actuating components (e.g. carrying handle) can be a crushing hazard!
- Tripping hazard!

If components with reed contacts or hall sensors are used, strong magnetic fields can result in unwanted influences to the system. Additionally, magnetically conducting materials are to be kept away from the direct foot switch area!

The electrical connection may only be carried out by authorized personnel.

Components, especially pedals or other actuating elements, may not be disassembled or dismembered under any circumstances! If this happens the products need to be sent back immediately.

Errors and omissions excepted.